

---

Fitting instructions

---

Make: Mitsubishi

---

Pajero / Montero; 2007->

---





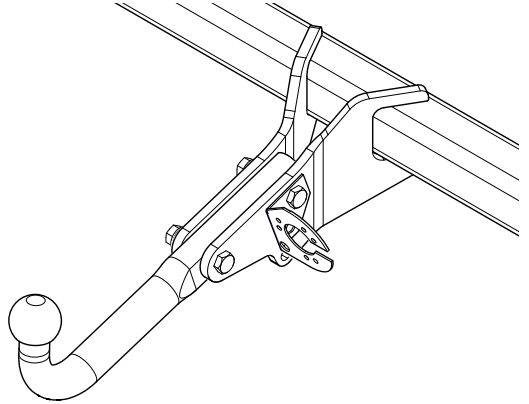

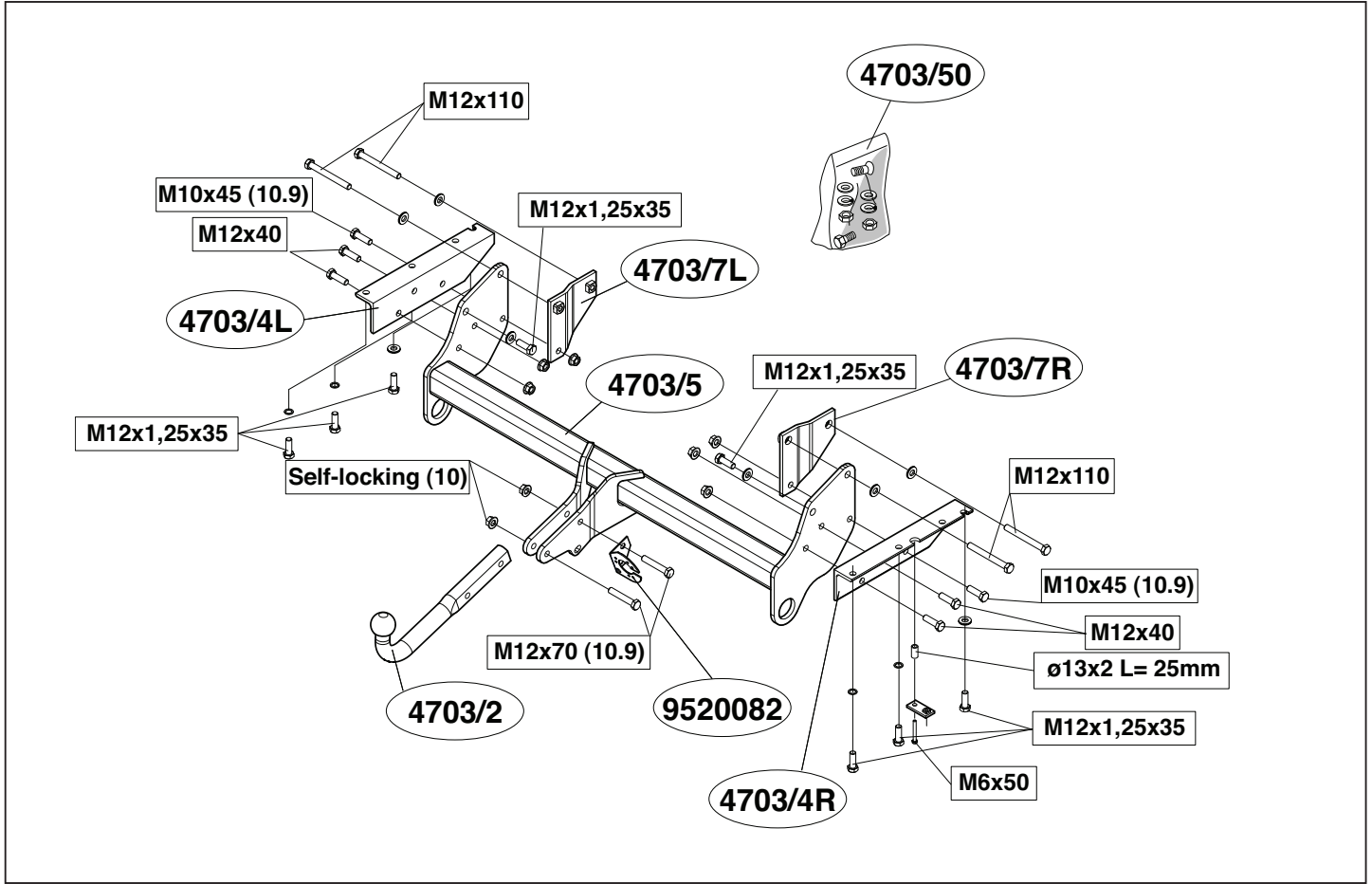

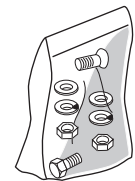
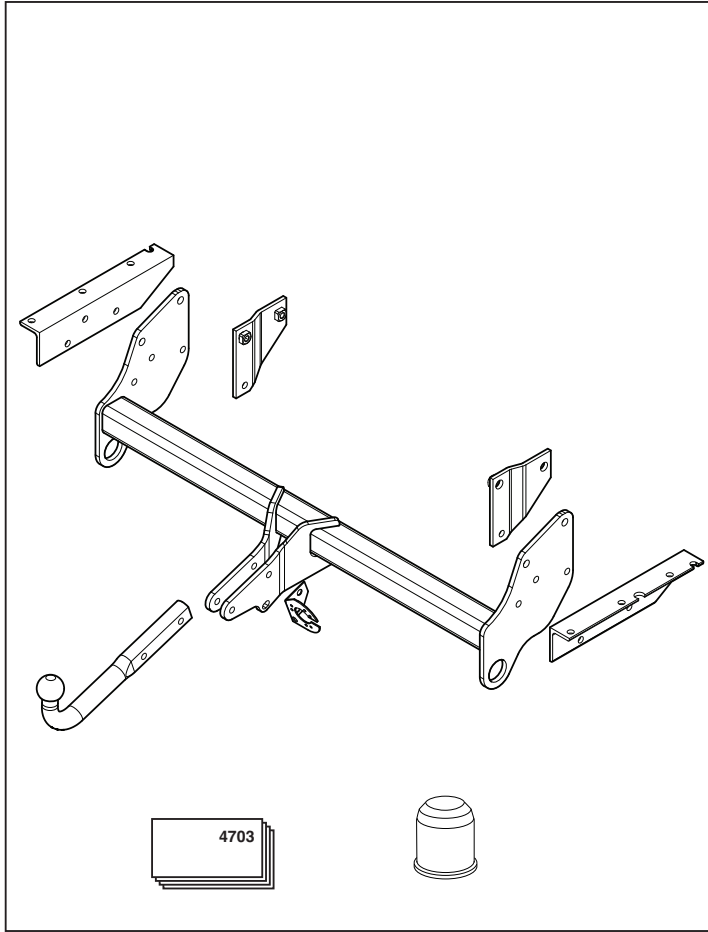



Type: 4703

---







-  (2x) M10x45 **(10.9)**
 (1x) 25x5L=54mm
-  (2x) M12x70 **(10.9)**
 (1x)  $\varnothing 13 \times 2$  L=25mm
-  (4x) M12x110
-  (8x) M12x1.25x35
-  (1x) M6x50
-  (4x) M12x40
-  (8x) M12
-  (2x) M10 self-locking **(10)**
-  (4x) M10
-  (18x) M12
-  (12x) M12

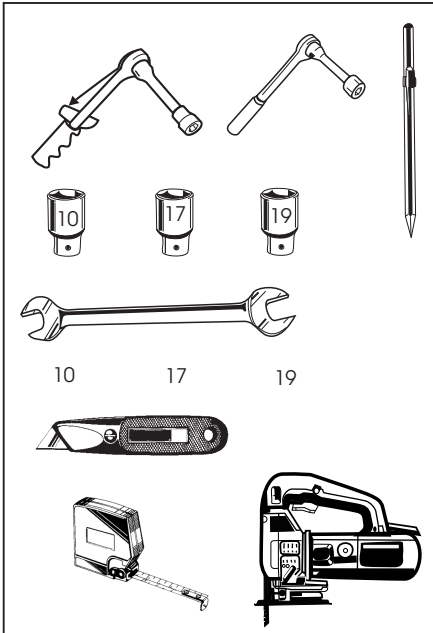

Couplingsclass: A50-X

euro tested

Approved

E11 55R 016042

ECE/R55

**D-Value : 16,3 kN**

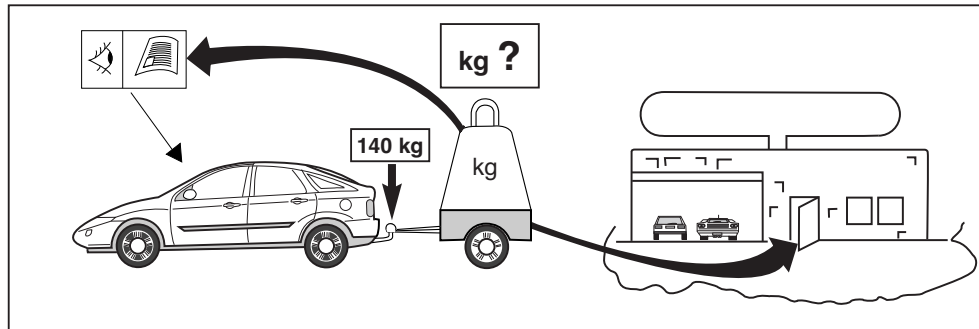

8.8

10.9

8

8

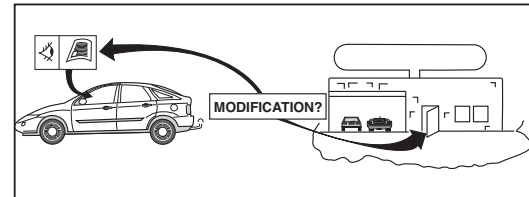

#### HINWEISE:

- \* Die für das Fahrzeug zugelassene Anhängelast ist den Fahrzeug Unterlagen zu entnehmen. Bei Änderungen des Fahrzeuggewichtes muß die höchstzulässige Anhängelast gegebenenfalls aus dem D-Wert nachgerechnet werden.  
Auskunft hierüber kann Ihr Fachhändler oder der TÜV geben.
- \* Elektrische Anlage gemäß STVZO anbringen.

#### NOTE:

- \* **Should this installation process entail the cutting of the bumper – conformation MUST be obtained by the installation engineer of the customer’s acceptance prior to completion. Brink International do not accept responsibility for any matters arising as a result of this miscommunication.**

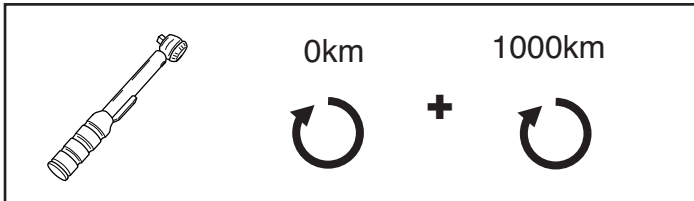

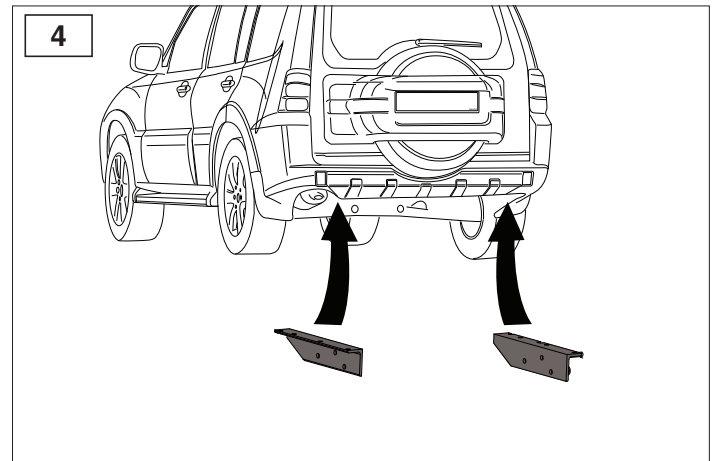
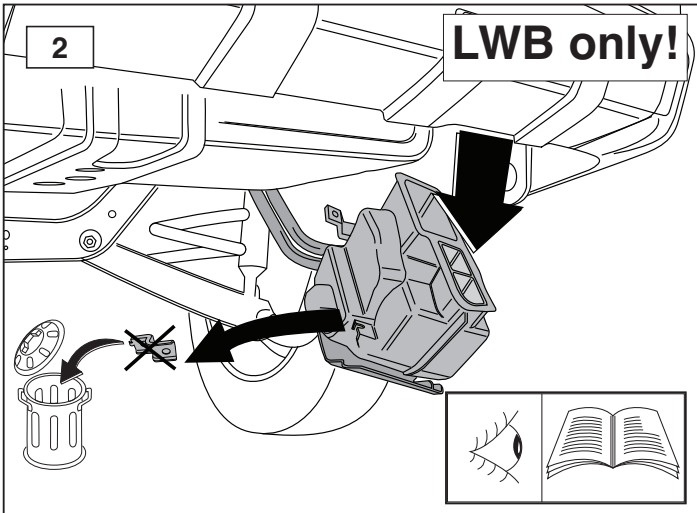
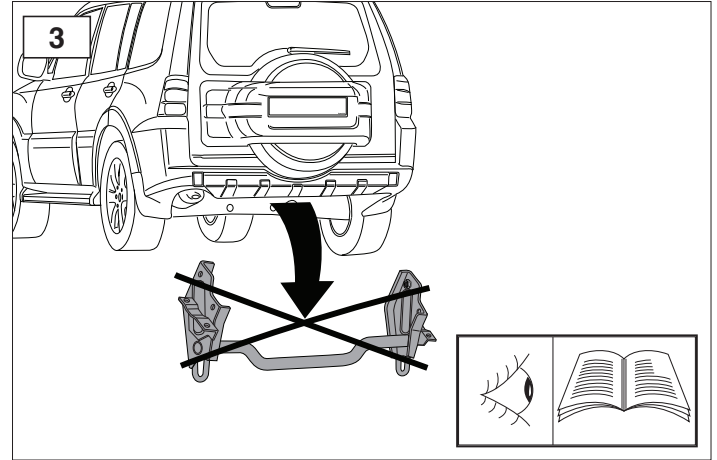
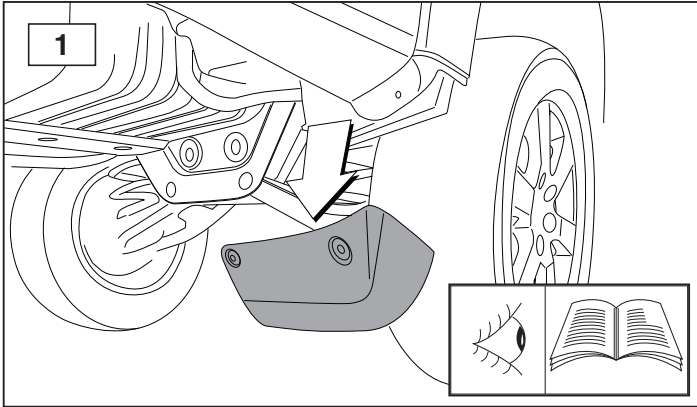

5

SWB

LWB

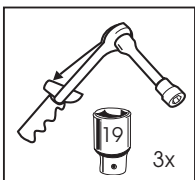
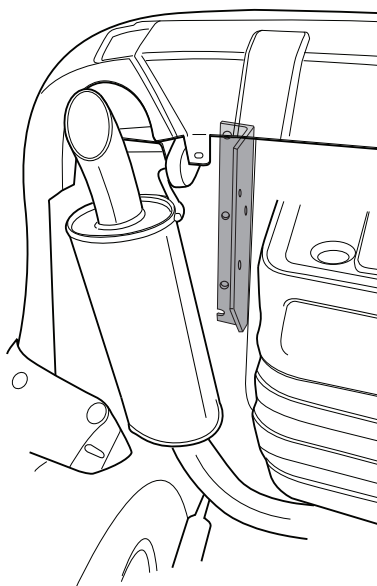

(3x) M12x1.25x35

(3x) M12

6

SWB

LWB

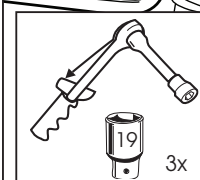
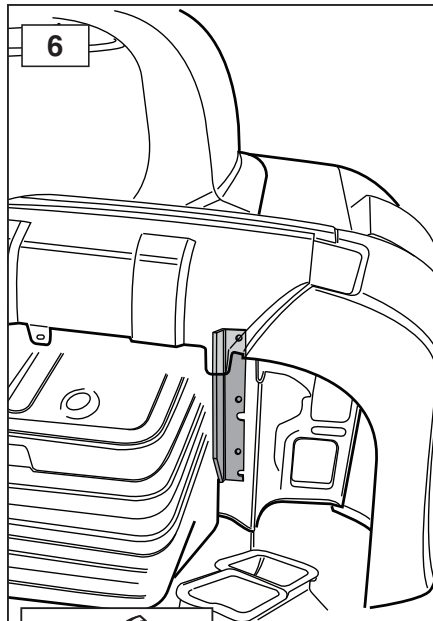





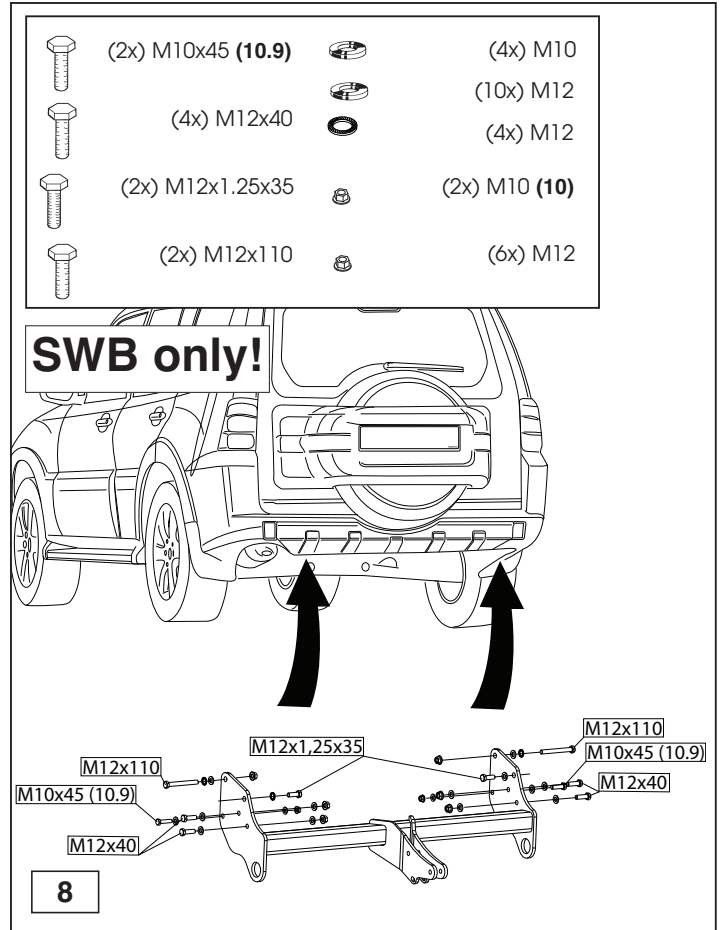
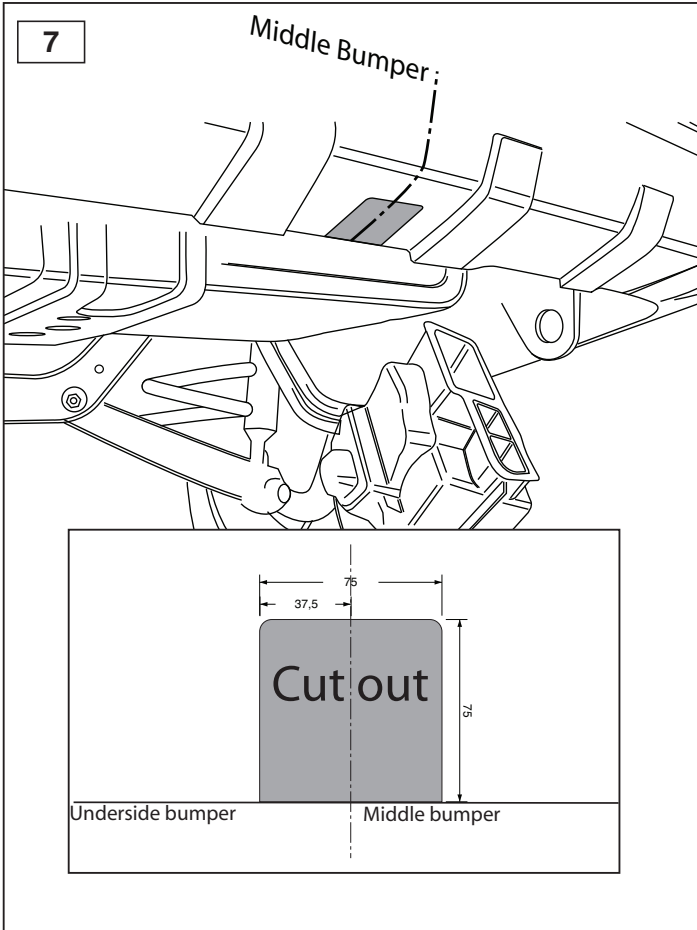



(3x) M12x1.25x35

(3x) M12





- |   |                    |   |               |
|---|--------------------|---|---------------|
|  | (2x) M10x45 (10.9) |  | (4x) M10      |
|  | (2x) M12x40        |  | (6x) M12      |
|  | (2x) M12x1.25x35   |  | (6x) M12      |
|  | (4x) M12x110       |  | (2x) M10 (10) |
|   |                    |  | (4x) M12      |

**LWB only!**

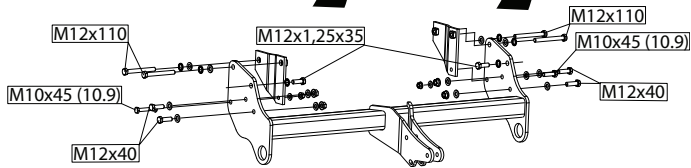
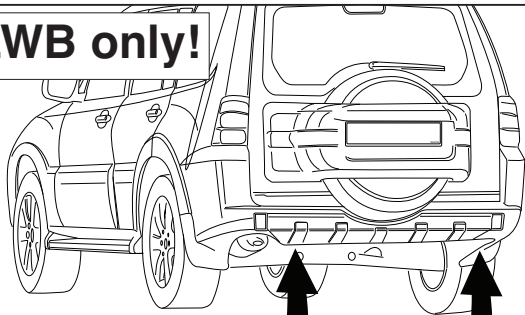

**9**

**10**

**SWB only!**

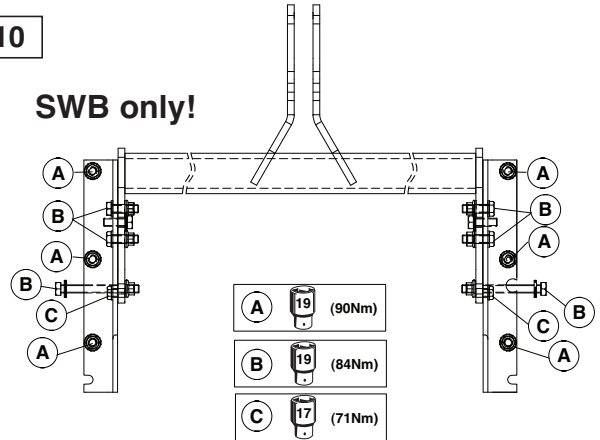

**LWB only!**

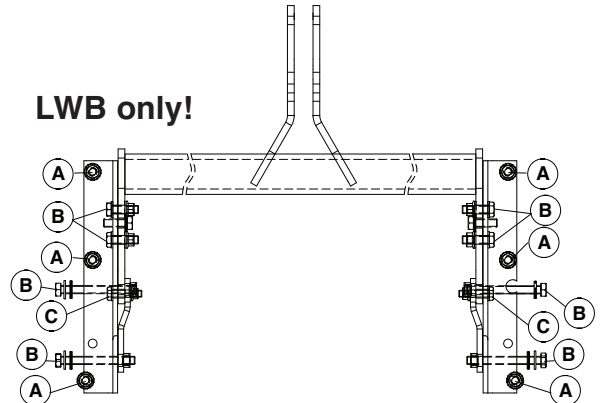

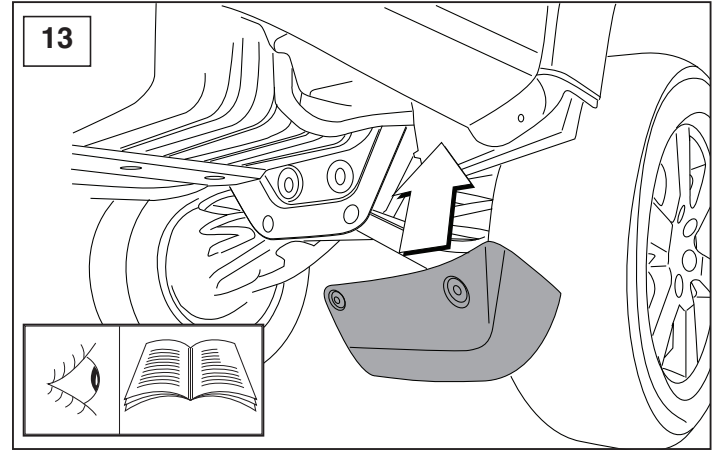
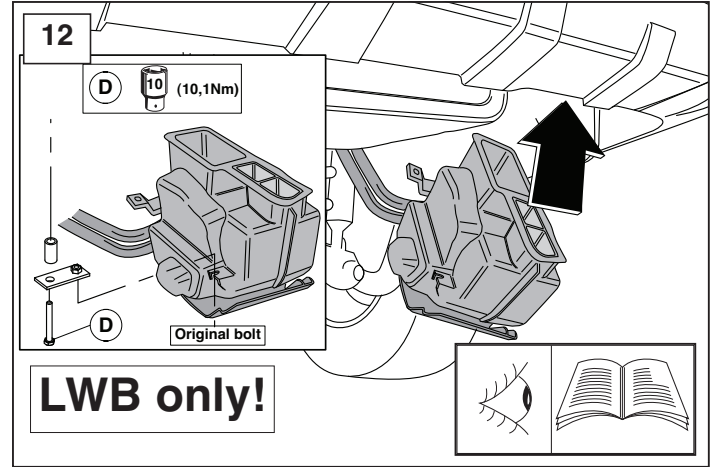
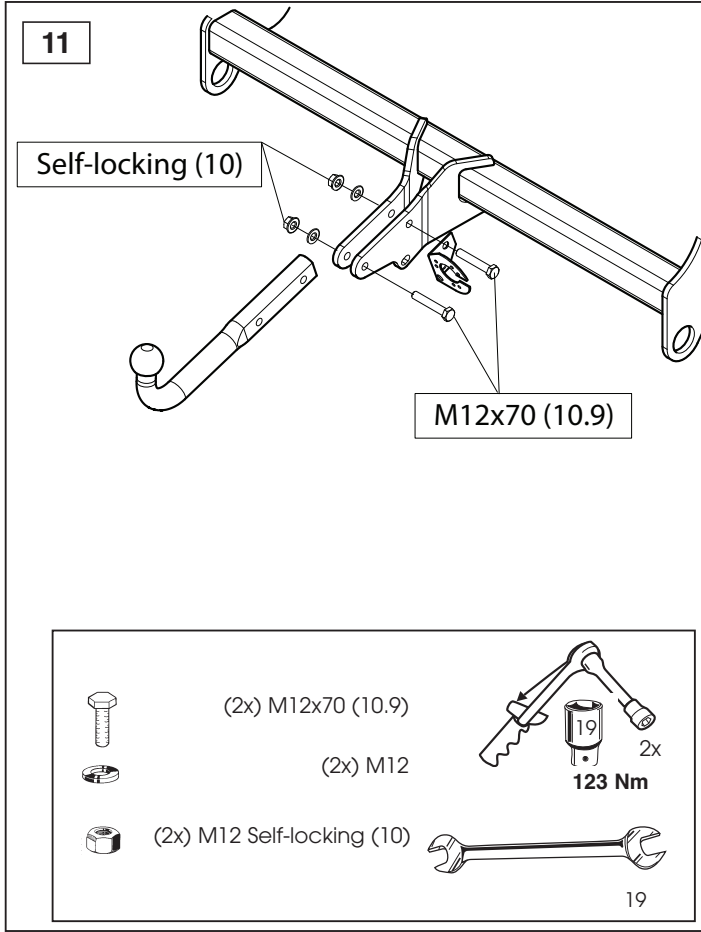



Dispositivo di traino tipo: 4703  
Per autoveicoli: Mitsubishi Pajero / Montero (SWB / LWB); 2007->  
Tipo funzionale:

Classe e tipo di attacco: A50-X  
Omologazione: E11 55R 016042  
Valore D: 16,3 kN  
Carico Verticale max. S: 140 kg

Larghezza rimorchiabile per Caravan e T.A.T.S.: 2,45m vedere CARTA di CIRCOLAZIONE VEICOLO (motrice) + 70 cm = ..arrotondare ai 5 cm superiore (vedi D.M.28/05/85)

Massa rimorchiabile: vedi carta di circolazione dell' autoveicolo

**Per verificare l' idoneità del dispositivo di traino omologato a norma CEE 94/20, all' installazione sulla vettura su cui si intende procedere al montaggio, compilare la seguente formula (se necessario declassare la massa rimorchiabile):**

$$D = \frac{T \times C}{T + C} \times 0,00981 \leq 16,3 \text{ kN}$$

dove: T= Massa Complessiva Max. della motrice (in kg)

C= Massa Rimorchiabile Max. della motrice (in kg)

## DA COMPILARE PER IL COLLAUDO

**DICHIARAZIONE DI CORRETTO MONTAGGIO:** la sottoscritta Ditta dichiara di aver montato in maniera corretta ed in conformità/ alle prescrizioni sia del costruttore del veicolo che del costruttore del dispositivo stesso il seguente dispositivo di attacco meccanico:

tipo:.....

Il dispositivo di attacco sopra indicato è stato installato su autoveicolo

modello:.....

targa:.....

Data:.....

**TIMBRO e FIRMA**

**Si dichiara inoltre di aver informato l'utente del veicolo sull'USO e MANUTENZIONE del dispositivo stesso.**